

# Model **SFP**

## Pneumatic Type Level Switch



# Pneumatic Type Level Switch

**Model** SFP-1A, SFP-3 For High-Viscosity liquid Sewage, oil etc...  
SFP-500E Explosion proof d2 G4...

The pneumatic level switch can be used for all sorts of liquids and is specially suitable for high-viscosity liquids. Because of its small size, it serves adequately as a control unit built in mechanical equipment.

## Principle

Liquid pressure is transferred through a pipe to the air room inside the switch unit, and air pressure is received by the diaphragm and energizes the micro-switch.

## Features

■ **Ensures almost no maintenance because of less movement of the operative parts.**

The diaphragm operated by water pressure moves 1-2m/m only and is therefore free from fatigue, abrasion and resultant troubles.

■ **Care free from such troubles as corrosion and adhesion.**

The liquid being measured does not contact the switch but the air pipe only. To use it for a higher-viscosity liquid, enlarge the air pipe end.

■ **Stabilized behavior.**

It uses a highly efficient micro-switch because there is a difference between the working point and the resetting point. It is kept from chattering though waves may arise on the liquid surface.

■ **Easy to install.**

It can be easily mounted to a base provided with a screwed 1" gas pipe.

An air pipe of 1/2" can be directly screwed into the body with ease whether it is a stainless pipe or a polyvinyl chloride pipe.

## Applications

Various chemical equipment for industrial use, Water disposition equipment, Air conditioning equipment, Asphalt plant, Transportation equipment, Various equipment for ships.

Heavy oil tank, Lubricant tank, Centrifugal separator, Stirring tank, Water making equipment, Foodstuff & Beverage manufacturing machine, Filler, Cleaner, Water heater, Washer, etc.

## Specifications

Item	Model	SFP-1A	SFP-1S	SFP-3	SFP-5B	SFP500E
Scope	Upper & lower limit detection for air release tank (Atmosphere)					
Construction	Water-Proof		Non proof	Water-Proof	Explosion proof	
Switch Rated	AC250V 10A	AC250V 10A	AC250V 10A	AC250V 10A	AC250V 10A	
Work point <sup>m/m</sup>	70 ± 5	65 ± 5	65 ± 5	130 ± 5	80 ± 5	
Reset point <sup>m/m</sup>	40 ± 5	45 ± 5	45 ± 5	80 ± 10	45 ± 5	
Differential <sup>m/m</sup>	30 ± 5	20 ± 5	20 ± 5	50 ± 10	30 ± 5	
Material Cover	ADC-12	ADC-12	SS plated	AC-4B	AC-4B	
Main Body	ADC-12	ADC-12	Phenol resin (Black color)	AC-4B	AC-4B	
Chamber	ADC-12	SCS-12		SUS 304	AC-4B	
Diaphragm	Neoprene	F-rubber	Neoprene rubber	SUS 304	Neoprene rubber	
Wire Gland	JIS F-20a	JIS F-20a	Bush rubber	JIS F-20a	PF 3/4	

When the liquid level rises until the air pipe end submerges in the liquid and required liquid pressure is applied to the air pipe end opening, the micro-switch is turned on automatically. The liquid level at this time, expressed by the distance from the pipe end, is termed to "resetting point". When the liquid surface lowers and the switch is set to OFF then liquid level expressed by the distance from the pipe end, is termed the "resetting point" and the difference between the working point and the resetting point, is "differential". These are measured on the assumption that the liquid is the same as water.

## Overall Dimensions

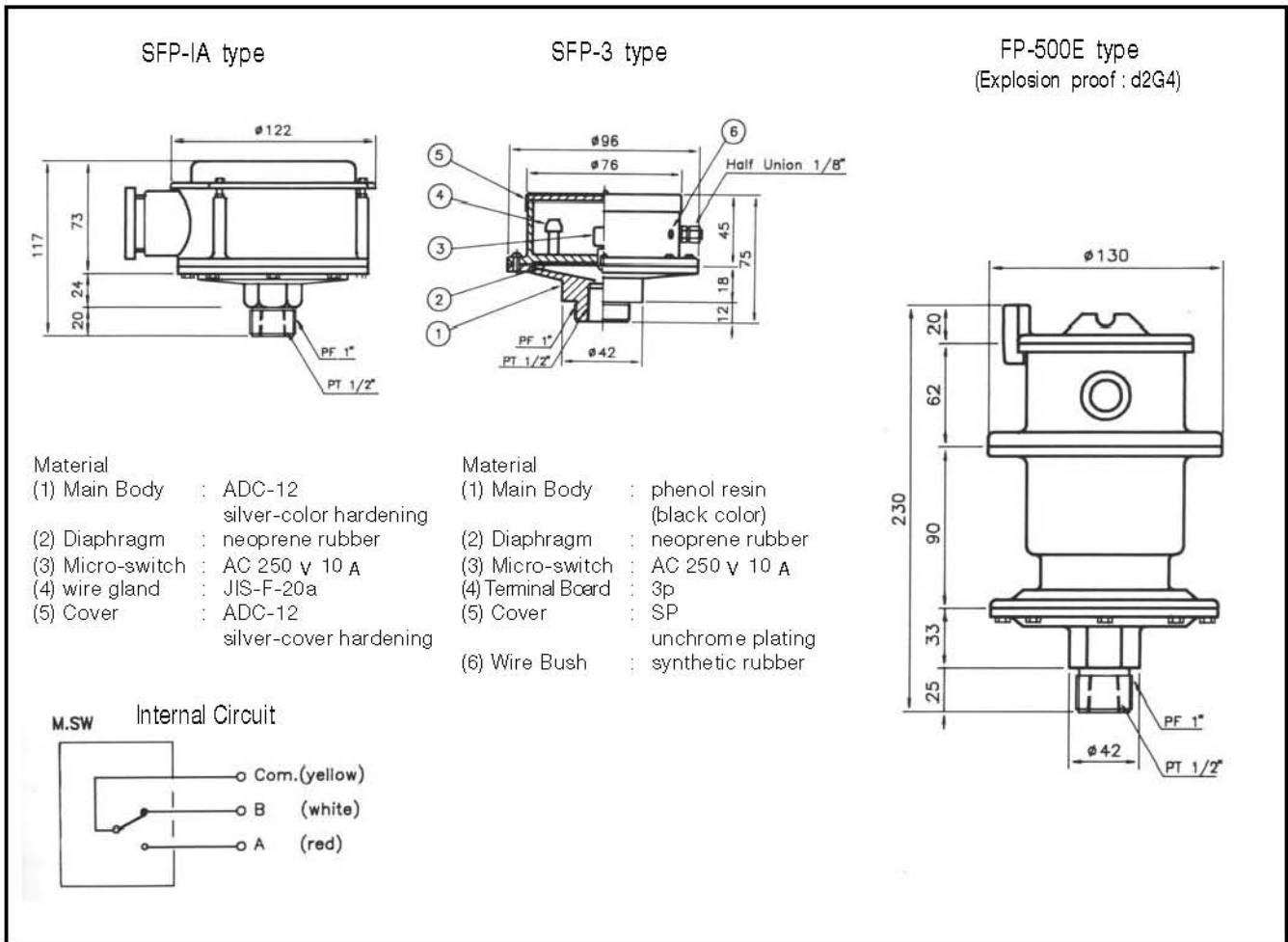

## Directions for Use

See Figs. 1~3 showing examples of mounting.  
 For connection between the switch and air pipe,  
 make air-tightness completely.  
 Mount it keeping the diaphragm in horizontal.  
 For a liquid other than water, calculator the  
 values of the working point and resetting point  
 from those measured with water conforming to  
 the standard specifications. (Divide by the  
 specific gravity of the measured liquid.)  
 When temperature inside the tank gets higher,  
 straighten the pipe between the tank and the  
 switch, and separate the switch from the tank.  
 Such a failure that the working point becomes  
 abnormal or the switch cannot be reset after  
 having been set to the OFF position, can be  
 easily corrected by sliding the micro-switch  
 up and down.  
 For FP-1, connect the wire directly to the micro-  
 switch terminal with care to keep the micro-  
 switch position from deviating.

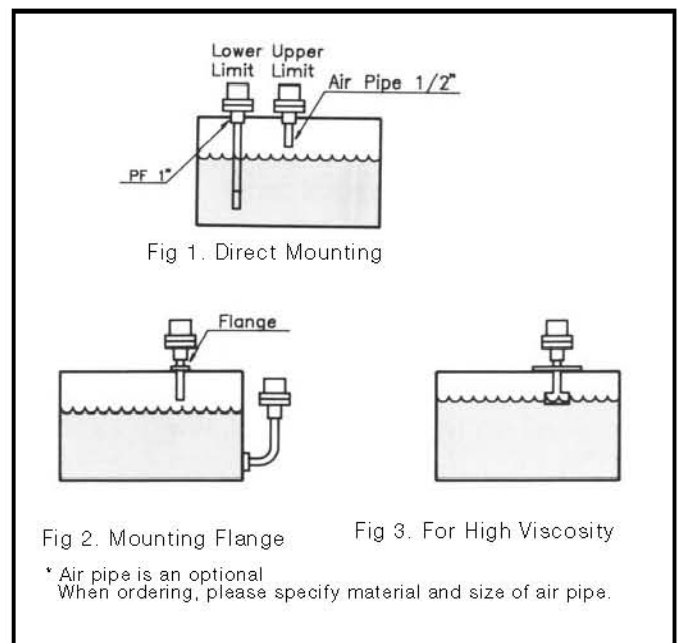

■ PNEUMATIC TYPE LEVEL SWITCH

SFP - 1A A 1 A 1

**CONDUIT CONNECTION**

- 1 = PF 1/2" (Std.)
- 2 = PT 1/2"
- 3 = PF 3/4"
- 4 = PT 3/4"
- OP= etc.

**ENCLOSURE**

- A = Weather Proof
- B = Explosion Proof (d2 G4); 500E Type

**MOUNTING SIZE**

- 1 = PF 1" Only(Std.)
- OP = etc.

**MEASURING CHAMBER MATERIAL & LENGTH**

- A = None(Std.)
- B = 304SS 1" Pipe PT 1/2" (Std. Per 1,000mm)
- C = PVC 1" Pipe PT 1/2"(Per 1,000mm)
- OP = etc. (Special Diameter & Special Material)

**TYPE OF SENSING PARTS**

- 1A = Standard type. Atm' Only. Neoprene diaphragm. NEMA4. ADC
- 1S = Fluoric rubber(Biton) diaphragm
- 3 = Economic type. Non weather proof. Phenol + C.S Cover

■ When placing an order, selected ordering number should be indicated on the purchase order sheet.